

Forme · Formes · Shapes · Formen · Formas

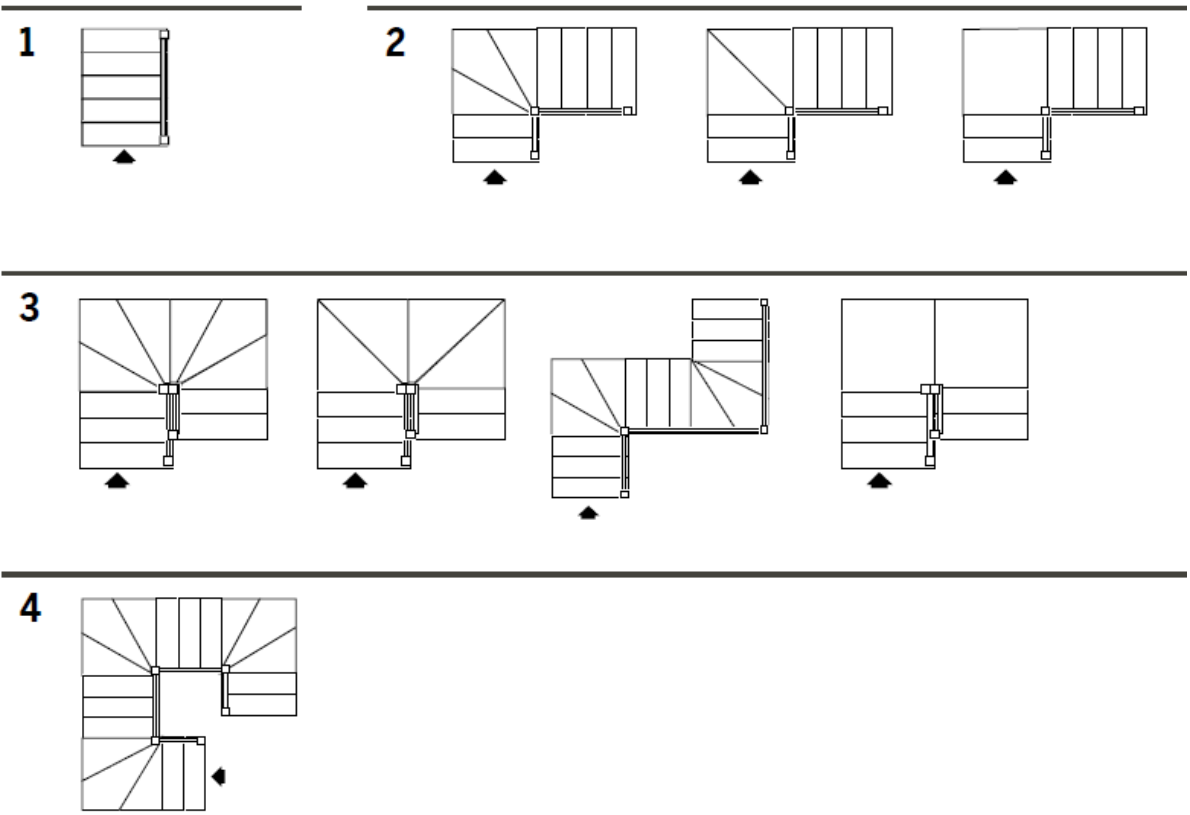

	G10	G11	G12	G13	G14	G15	G16	G17
h	1870	2040	2210	2380	2550	2720	2890	3060
G1	2310	2520	2730	2940	3150	3360	3570	3780



LE FORME DELLA STRUTTURA

The shapes of the structure

Les formes de la structure

Die Formen der Struktur

Las formas de la estructura

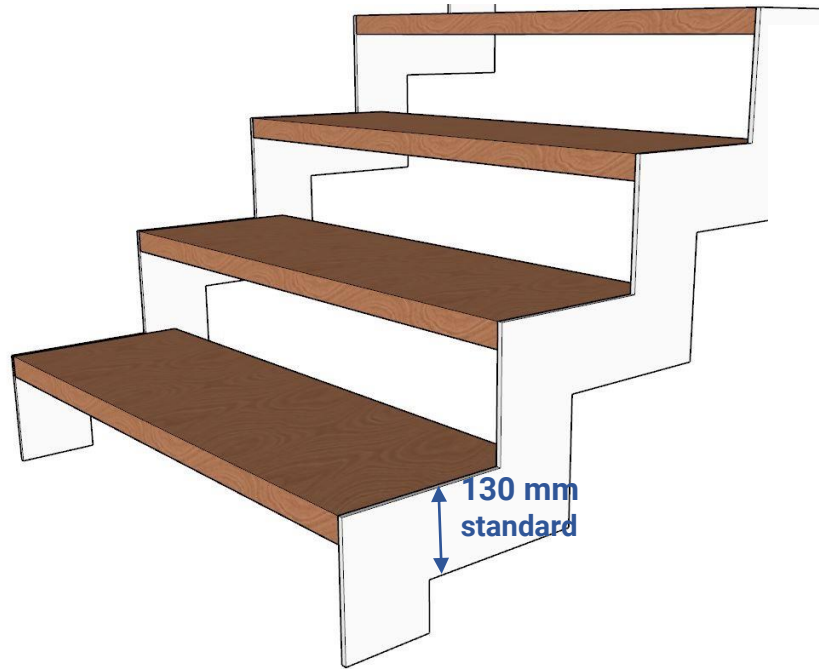

Z
(standard)

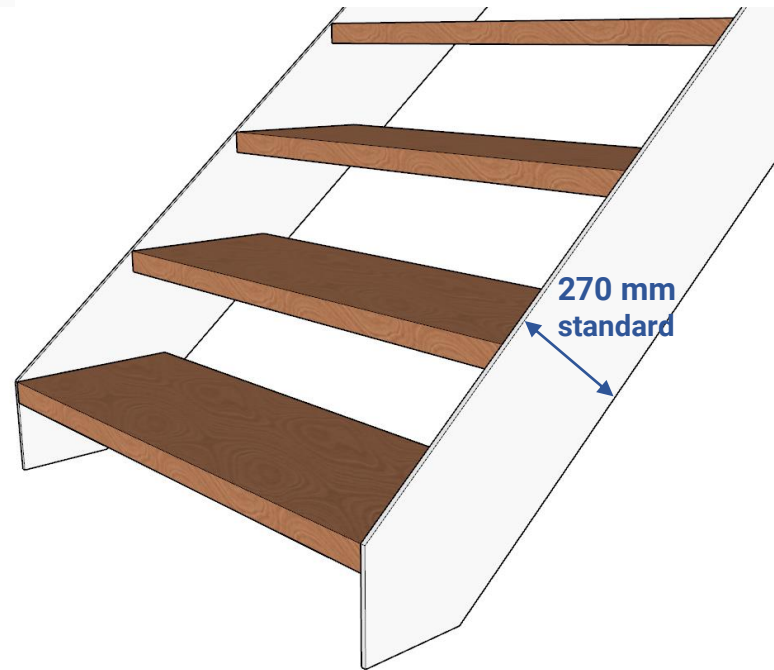

L
(optional)

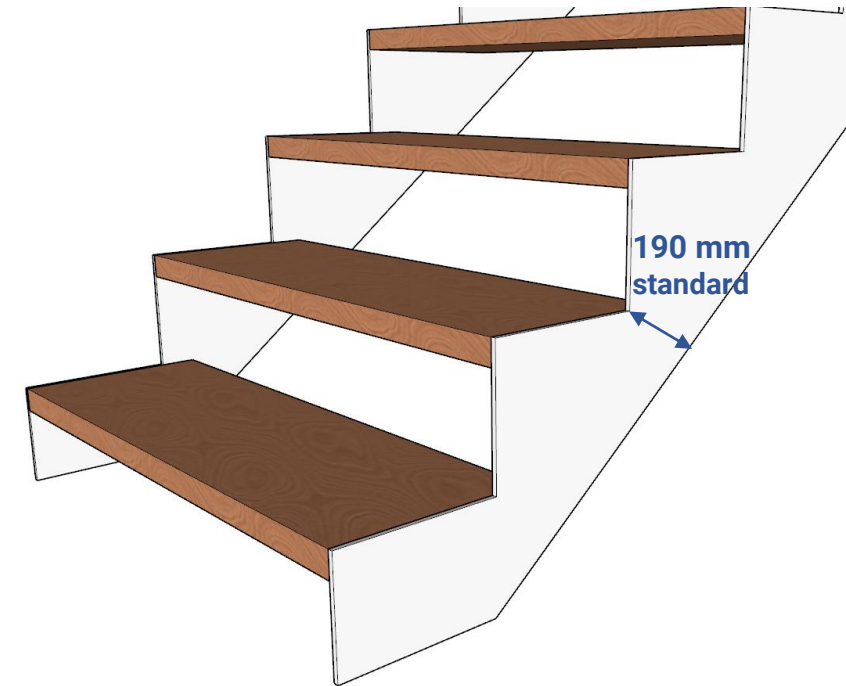

ZL
(optional)

LE FORME DELLA RINGHIERA

Type of banister - Types des garde-corps -
Arten von Geländern Tipos des barandilla



SC



CZ



CHROME

Caratteristiche tecniche

Technical specifications
 Spécifications techniques
 Technische Daten
 Características técnicas

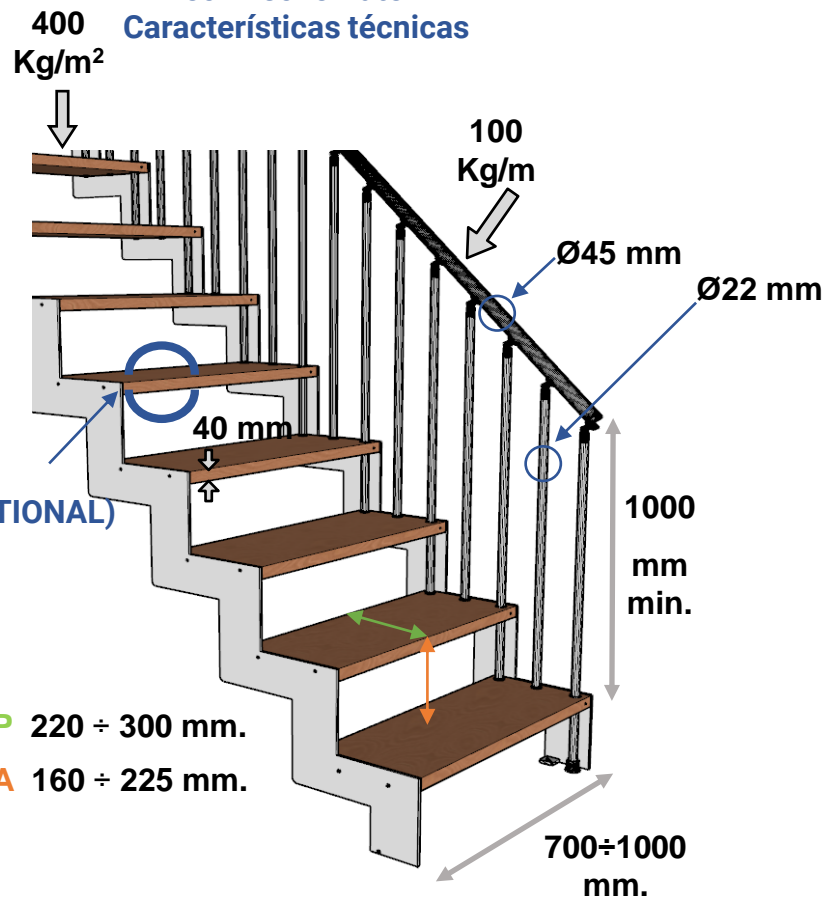

Tipologie di legno disponibili

Type of Wood
 Type de bois
 Holzart
 Tipo de madera



Faggio
 Beech
 Hêtre
 Buche
 Haya



Rovere
 Oak
 Chêne
 Eiche
 Roble

Calcolo passaggio utile

Useful passage - passage utile
 -nützliche Passage - Pasaje útil

$$L - R (60 \text{ mm}) = P$$

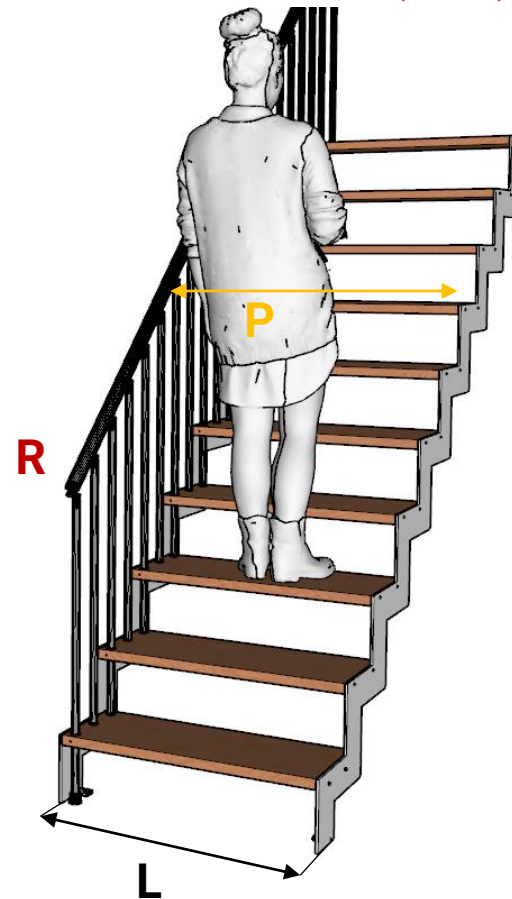

Caratteristiche tecniche

Technical specifications
Spécifications techniques
Technische Daten
Características técnicas

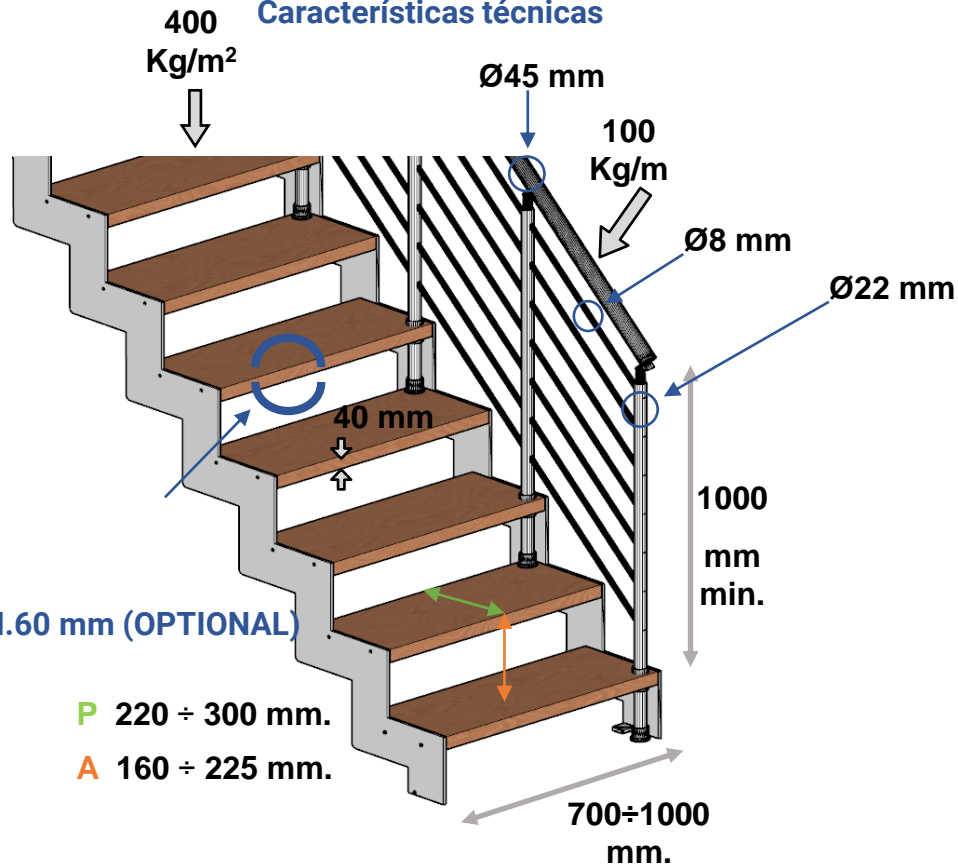

Tipologie di legno disponibili

Type of Wood
Type de bois
Holzart
Tipo de madera



Faggio
Beech
Hêtre
Buche
Haya



Rovere
Oak
Chêne
Eiche
Roble

Calcolo passaggio utile

Useful passage - passage utile
-nützliche Passage - Pasaje útil

$$L - R (60 \text{ mm}) = P$$

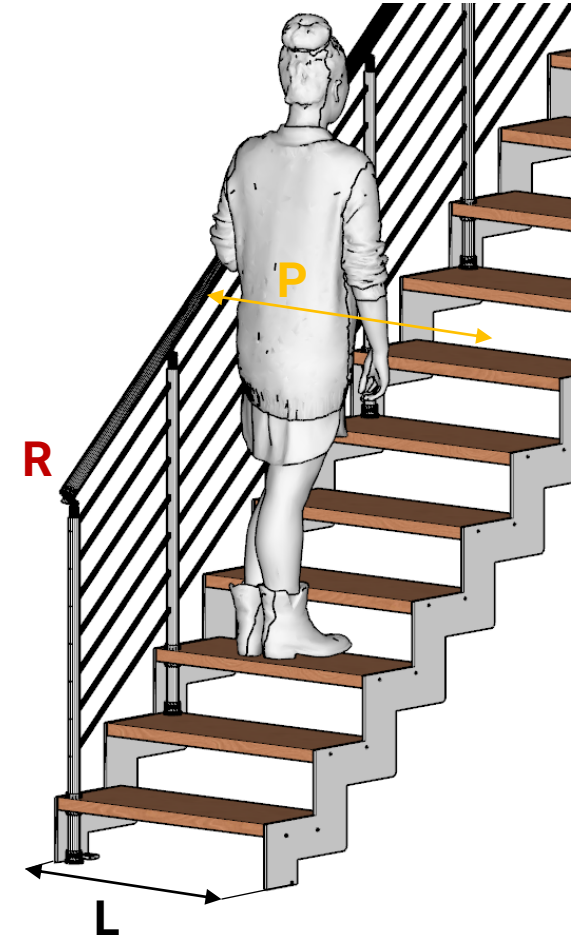

ARRIVO CON ALZATA
ARRIVAL WITH RISER
ARRIVÉ AVEC HAUTEUR
ANKUNFT MIT STEIGUNG
LLEGADA CON CONTRAHUELLA

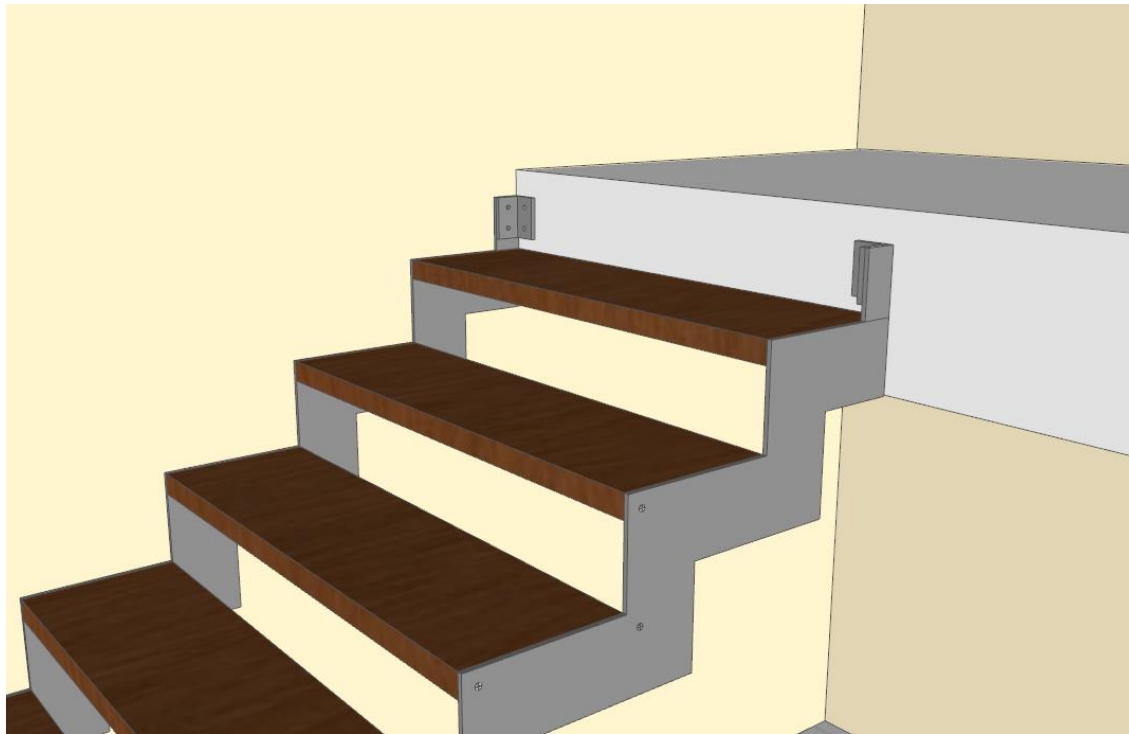

ARRIVO PARI PAVIMENTO
ARRIVAL AT SAME FLOOR LEVEL
ARRIVÉE AU MÊME NIVEAU DU SOL
ERREICHUNG GLEICHEN NIVEAU DES BODENS
LLEGADA MISMO NIVEL QUE EL SUELO

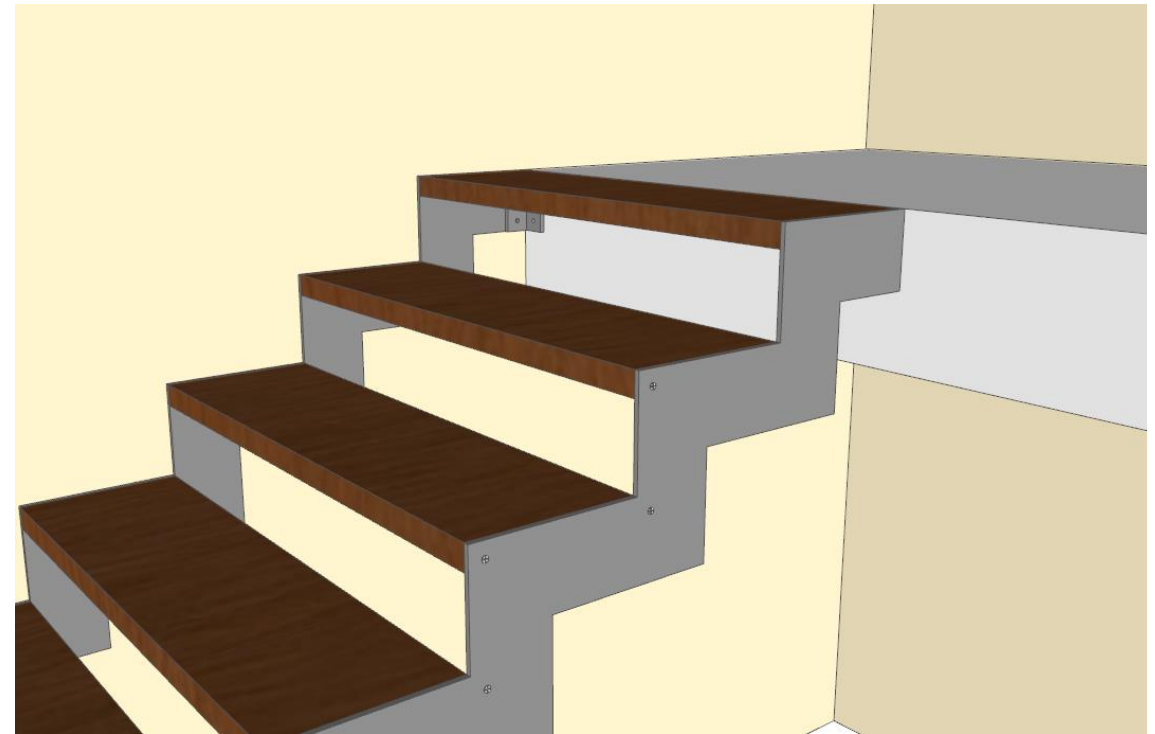

PARTENZA DA PAVIMENTO

FLOOR DEPARTURE - DÉPART DU SOL - ABGANG VOM BODEN - SALIDA DESDE EL SUELO

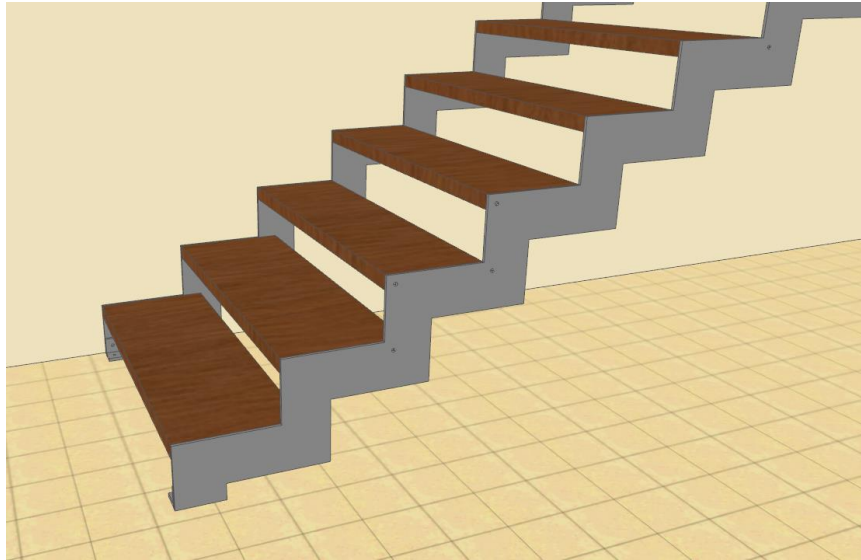

PARTENZA A SBALZO CANTILEVER DEPARTURE

-DÉMARRAGE EN PORTE-À-FAUX - ÜBERHANGSTART - ARRANQUE EN VOLADIZO

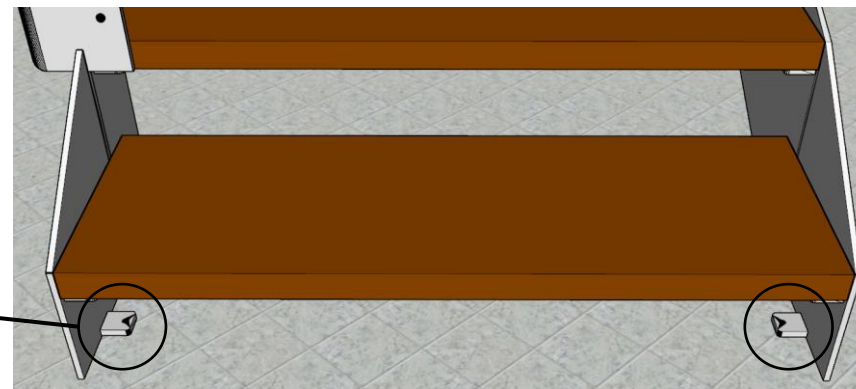
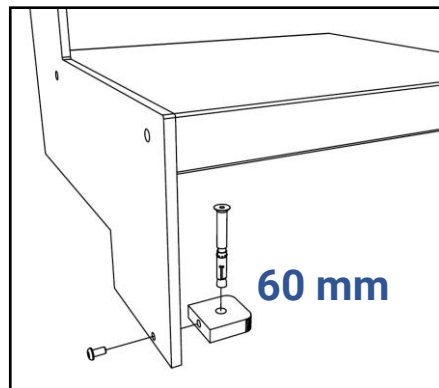
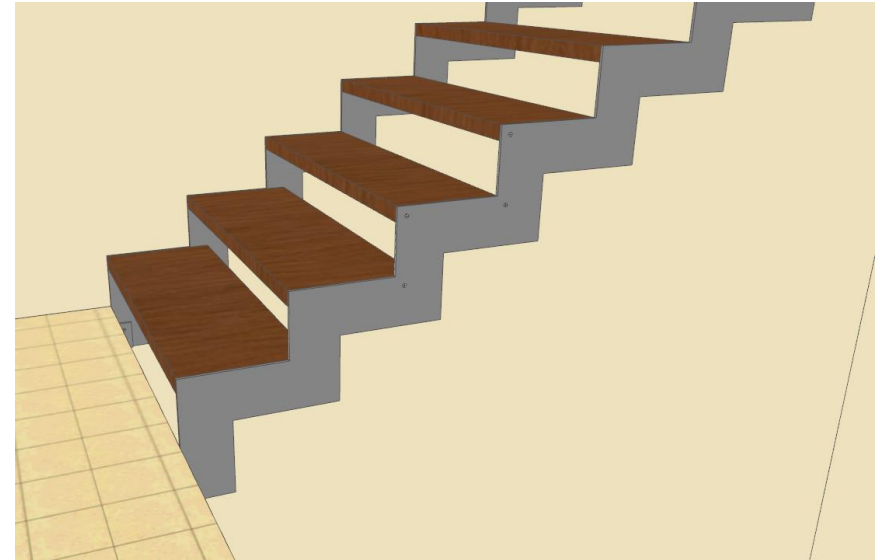

FISSAGGIO A PAVIMENTO

FLOOR FIXING
FIXATION AU SOL
BODENBEFESTIGUNG
FIJACIÓN DEL SUELO

CHROME

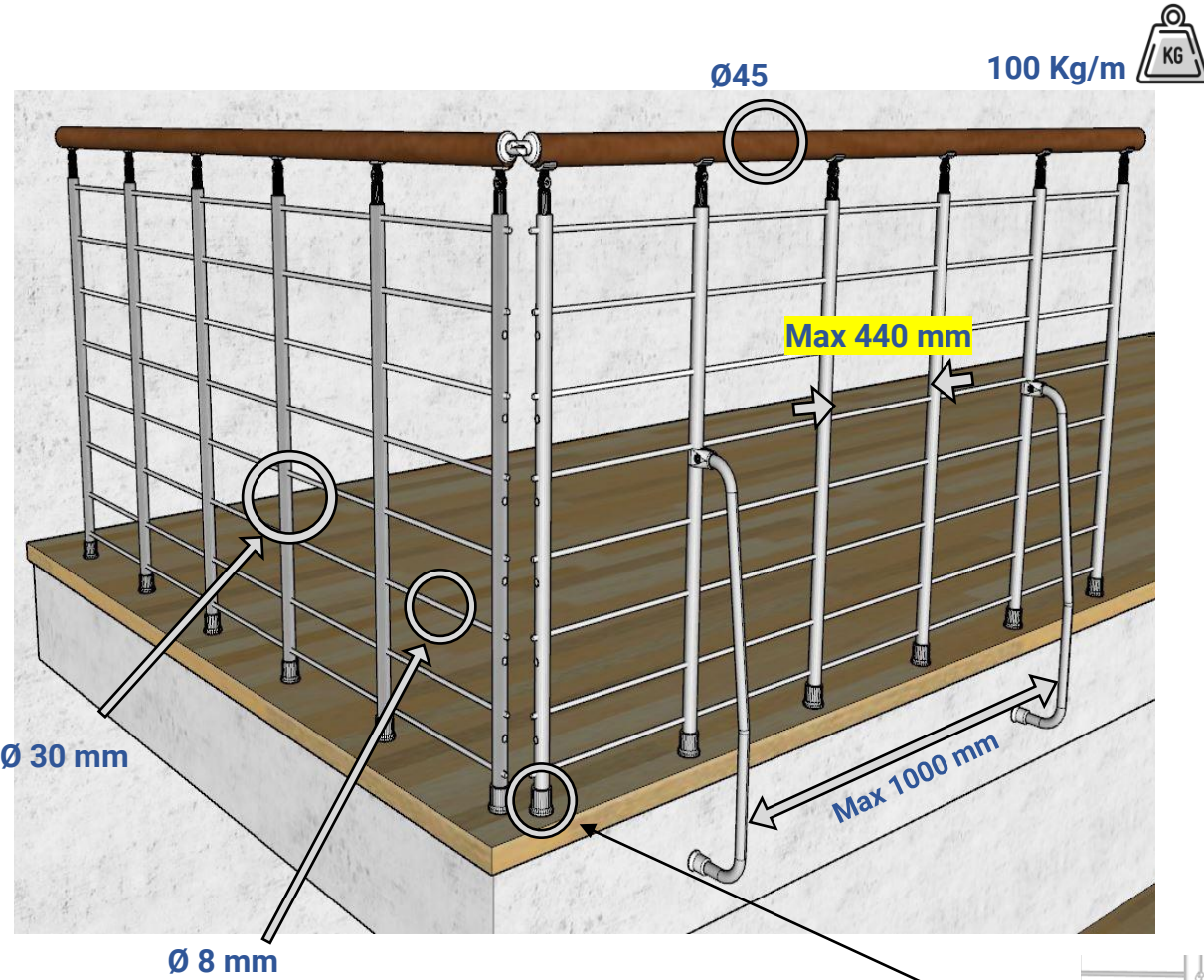

CZ/SC

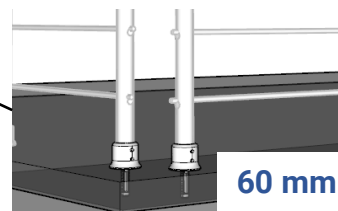
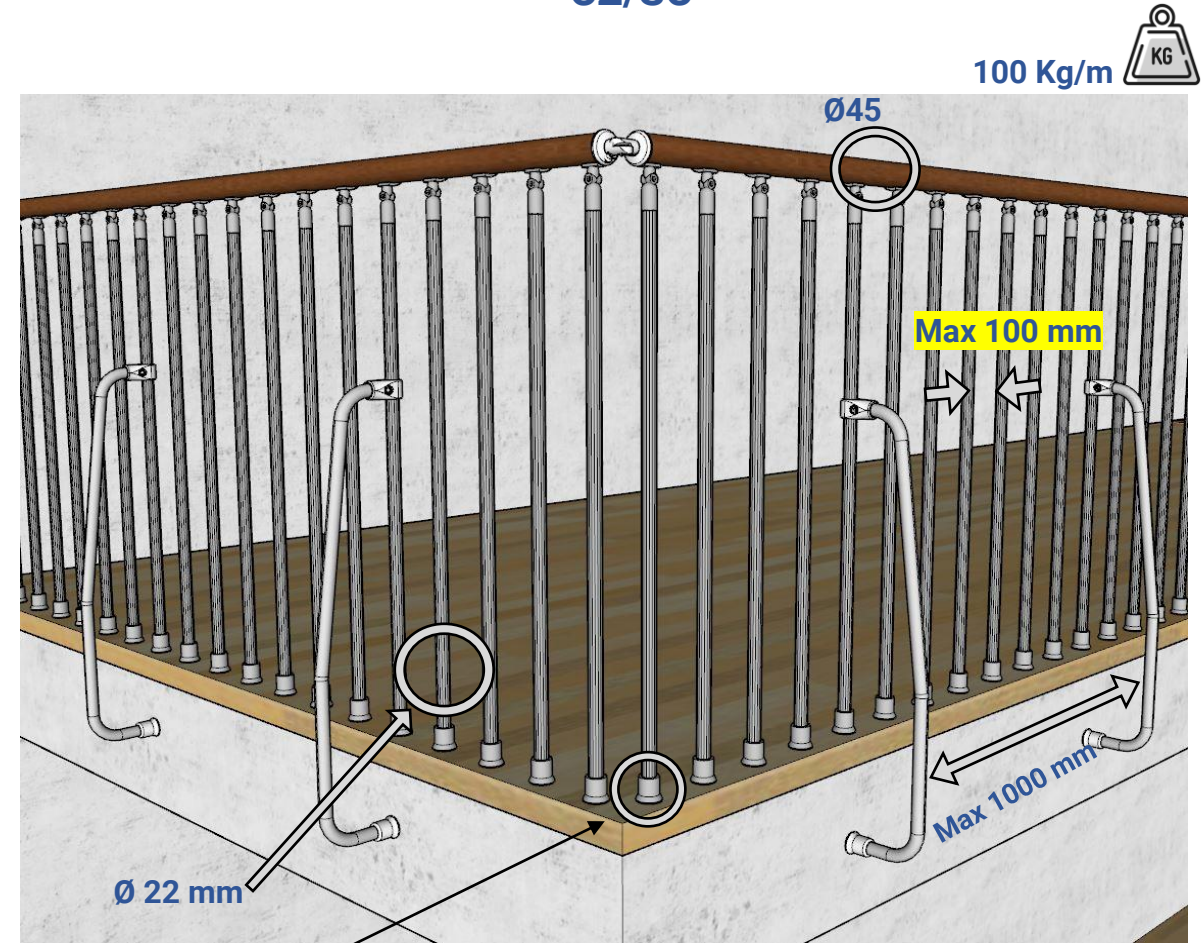

Alzate chiuse

Closed Risers – Contremarches
Setzstufen – Contrahuella cerrada

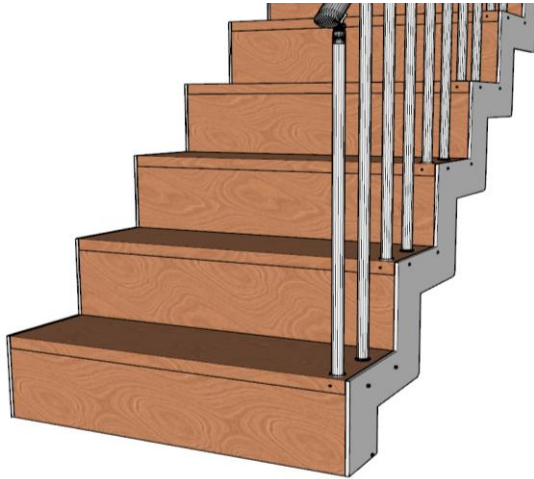

Angolo per pilastro (max 3 gradini)

Corner for Pillar (max 3 steps) – Angle pour Poteau (max 3 marches)
Winkel pro Säule (Max 3 Sufen) - Angulo por pilar (máximo 3 escalones)

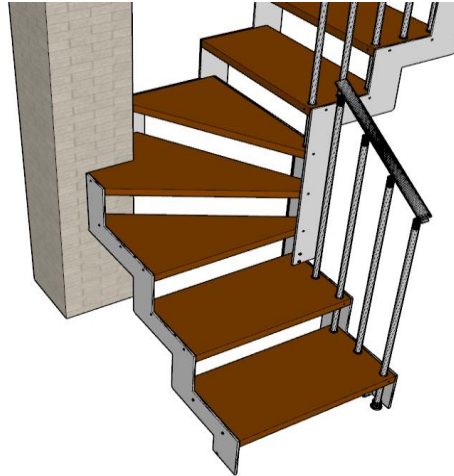

Scala fuori squadra

Out-of-square stair - Escalier hors équerre
Unregelmäßige Treppe – Escalera fuera de escuadra

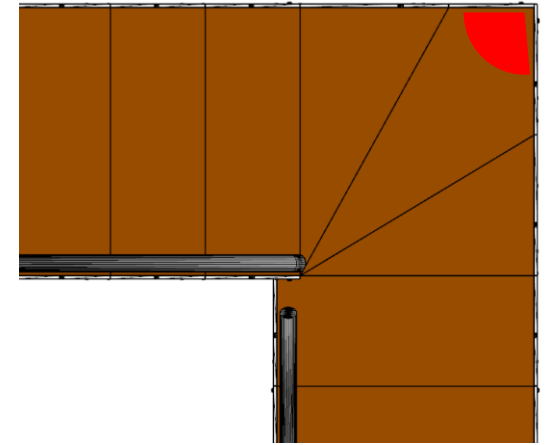

Corrimano a muro

Wall handrail – Main courante murale
Wandhandlauf - Pasamanos de pared



Larghezza scala

Staircase width – Largeur escalier
Breite der Treppe- Anchoe escalera

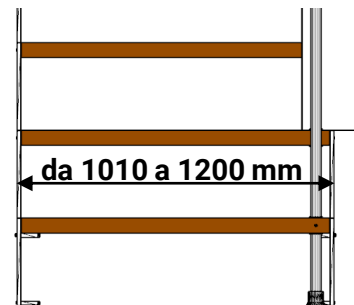

Soglia

Threshold – Seuil – Schwellenwert - Umbral

